

BARTON Chart Recorders

Models 202E, 202N, 242E and J8A

Cameron's BARTON® chart recorders are the industry standard for accurate, reliable measurement and recording of pressure, differential pressure and temperature in a variety of applications. In addition, DP models utilize BARTON rupture-proof bellows DPU as the actuating unit – and DP models have features like overrange protection and pulsation dampening (on some models).



Common Components

- **Case** – The case is made of rugged, lightweight die-cast aluminum that features a built-in rainshield. It is finished in polyurethane electrostatic powder paint that has a high resistance to weathering, scratches, and industrial fumes. An aircraft-type door hinge (made of 302 SST) provides excellent resistance to salt spray and H₂S. The seal between the door and the case is made of neoprene, a material that is non-absorbant and resistant to oils and most solvents.
 - Optional "S" versions use a stainless steel case or a corrosion-resistant offshore coating for harsh, saltwater environments.
- **Chart Drive** – Chart drives are available in battery and spring-wound versions with a wide variety of chart speeds. All chart drives have a simple, positive chart lock hub and are interchangeable.
- **NUFLO™ Charts** – The charts are made from wood-free paper – a special, low-shrinkage, high quality product that eliminates eccentric and elliptical errors. Charts are shrink-wrapped to help maintain the factory default size until the package is opened by the user. Once a box of charts is opened, it can be stored in the supplied, plastic, resealable storage bag.
- **Recording Mechanism** – All parts are stainless steel for long life. The pen mount is exceptionally rugged and pen shafts are fitted with ball pivots to minimize friction. All links are adjustable, with micrometer adjustments for accurate calibration. All adjustments have screwdriver slots to simplify calibration. Disposable pens are standard.
- **Pressure Elements** – Used in Models 202E, 242E and J8A are precision wound helical-type available in a variety of materials – pressure ranges up to 30" mercury vacuum (up to 14.7 psi/1 bar), up to 30,000 psi (up to 2068 bar). The Model 202N uses a K-monel element – pressure ranges up to 250 psi (up to 17 bar), up to 6000 psi (up to 414 bar). Connections available in 1/4" NPT for ranges less than 10,000 psi (689 bar). Ranges greater than 10,000 psi (689 bar) utilize an Aminco 9/16–18 (1/4" ODT) female connection.
- **Thermal Systems** – The systems consist of a bourdon tube, a capillary with stainless steel armor and a bulb with a bendable extension. All parts are stainless steel. Systems are available in Class V (mercury fill with an 11/16" OD bulb) or Class I (hydrocarbon fill with a 3/8" OD bulb). Temperature ranges for each design are listed below. A thermal system must have a span of more than 50° F (27° C) and the high temperature limit must be greater than 95° F (35° C).
 - **Class VA** (fully compensated) –40° F to 600° F (-40° C to 315° C)
 - **Class VB** (case compensated): –40° F to 600° F (-40° C to 315° C)
- **Class IA** (fully compensated) – temperature range varies with fill material
 - Ethyl-benzene: -125° F to 350° F (-87° C to 177° C)
 - Kerosene: -20° F to 500° F (-29° C to 260° C)
 - Alcohol: -200° F to 150° F (-129° C to 66° C)
- **Class IB** (case compensated) – temperature range varies with fill material
 - Ethyl-benzene: -125° F to 350° F (-87° C to 177° C)
 - Kerosene: -20° F to 500° F (-29° C to 260° C)
 - Alcohol: -200° F to 150° F (-129° C to 66° C)
- **Accuracy** ± 1.0% of F.S.
- **Hardware** Capillary standard length is 10' (additional lengths available)

Models 202E (DP)

The 202E is a 12" chart recorder that has been used widely in gas transmission and distribution fields because of its accurate calibration, even under extreme variations in static pressure and ambient temperatures.

The 202E is available in 1 to 4 pen configurations (DP+3 additional pens). The additional pens can be used to record temperature and supplemental pressure data.

The unit is actuated by a BARTON Model 199 DPU, with standard and NACE units available (up to 4500 psi/310 bar SWP) – see DPU bulletin #21700 for details. Static pressure and temperature pens are actuated by precision wound elements (see page 1).

Main Components

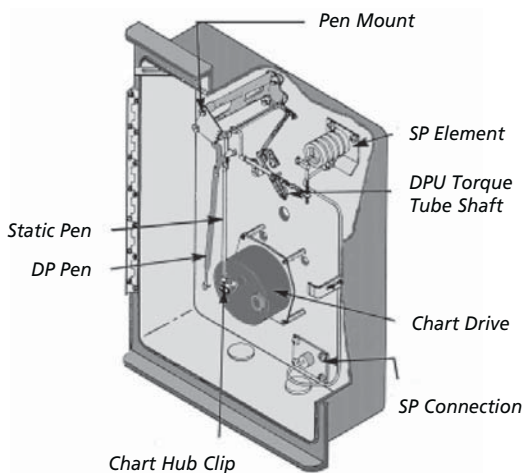

Specifications

Safe Working Pressure	up to 6000 psi (414 bar)
DP Ranges	up to 10" w.c, up to 100 PSID (up to 25 mbar, up to 6.9 bar)
Accuracy	± 0.5% F.S.
Temperature Limits	-40° F to 180° F (-40° C to 82° C)

Model 202N (DP) (NACE)

The 202N is a 12" chart recorder designed to measure flow, static pressure and temperature in sour gas applications. The 202N meets all NACE requirements for H2S environments, per MR-01-75 (1991 Revision) – SWP up to 2000 psi (138 bar).

For ranges between 2000 psi (138 bar) and 4500 psi (310 bar), see optional NACE version of M202E.

The 202N is actuated by BARTON's M199 NACE DPU. Static pressure measurements are provided by precision wound K-monel helical-type elements.

- All other features and benefits are the same as the 202E.

Specifications

Safe Working Pressure	up to 2000 psi (138 bar)
DP Ranges	up to 10" w.c, up to 100 PSID (up to 25 mbar, up to 6.9 bar)
Accuracy	± 0.5% F.S.
Temperature Limits	-40° F to 180° F (-40° C to 82° C)

Model 242E (Temperature/Pressure)

The 242E is a 12" chart temperature and pressure recorder designed for general pressure applications.

Specifications

Pressure Element Range	up to 30,000 psi (2068 bar)
Accuracy	± 1.0% F.S.
Temperature Limits	-40° F to 180° F (-40° C to 82° C)

Model J8A (Temperature/Pressure)

The J8A is a compact 8" chart temperature and pressure recorder designed for general pressure applications. Available as a single or dual pen unit, it can use any combination of pressure measuring helical elements or temperature measuring thermal systems.

- **Pressure Elements** – Same as those supplied for 12" recorders, with pressure ranges up to 30" Hg to 30,000 psi (0-14.7 psi/1 bar to 2068 bar).
- **Case** – A smaller version of the 242E, the J8A case is 3" thick, with a closed cell neoprene gasket. The standard door comes with an 8" square piece of glass, Plexiglas (Lexan), or 16-gauge steel plate for solid door applications.
- **Overall dimensions of standard unit** – 10.5" wide x 13.75" tall x 4 5/8" deep



Recorder Dimensions for Models 202 and 242

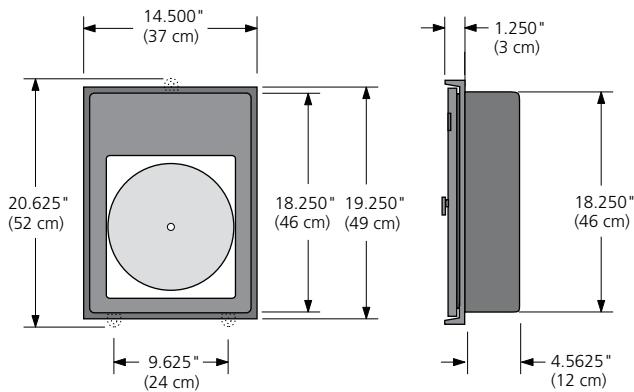

Recorder Weights

Ind. Model	202E/202N					
	Forged Steel			Forged SST		
	2500	4500	6000	1000	3000	6000
Safe Working Pressure (psi)	68 (31)	69 (31)	71 (32)	59 (27)	69 (31)	71 (32)

The M242E or J8A gross weight is approximately 25 lb (11 kg). For SST "S" versions, add 10 lb (6 kg) to standard weights.

Mounting Options

- Panel
- Wall
- Pipe mount, slip-on, non-thread (1-1/2" or 2" std. pipe)
- Portable stand, with handle
- Wall shock-mounting kit

Ordering

When ordering recorder, please specify the following items:

- Model number
- Housing pressure rating (SWP) (DPU models)
- Housing and bellows materials (DPU models)
- Process material contacting bellows (DPU models)
- Differential pressure range (DPU models)
- Pressure elements (range, material)
- Pens (disposable)
- Chart drive (type and rotation)
- Thermal systems (range, capillary length, class)
- Mounting (pipe, wall, flush panel, portable or shock mount)
- Charts